



	Model type				
	S	XS	M	XL	XL (CPW)
H (mm)	1385	1385	2045	2045	2045
B (mm)	594	1194	594	1194	1194
T (mm)	612	612	612	612	612
T1 (mm)	1100	1140	1100	1140	1140
Doors	1	2	1	2	2
Tare weight (kg)	220	390	310	520	530
Inside cabinet volume (m³)	0,28	0,61	0,43	0,95	0,95

CPW: Centre partition wall

### Outer dimensions

This drawing is our property! Furnish this information to other persons and reproduce or copy is not permitted without our written permission.	title: Safety cabinet type 90 BATTERY standard		
	drawing no: 000104997	page: 1 of 4	
Düperthal Sicherheitstechnik Frankenstrasse 3 D-63791 Karlstein	revision: 02	date: 2020-03-19	

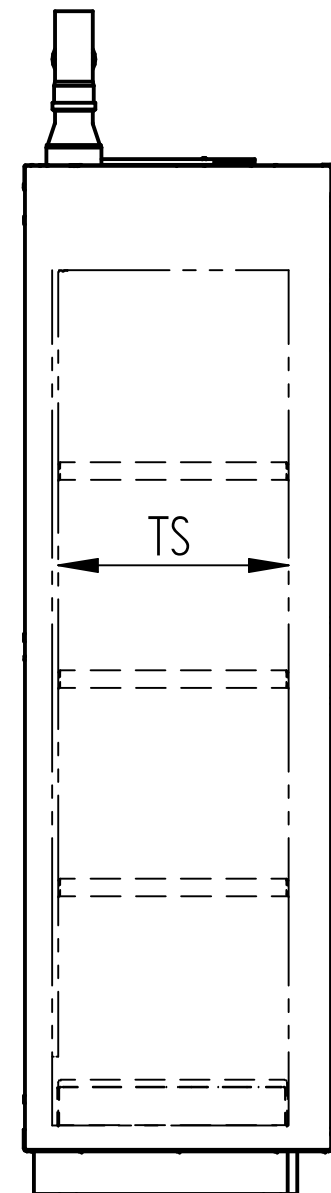
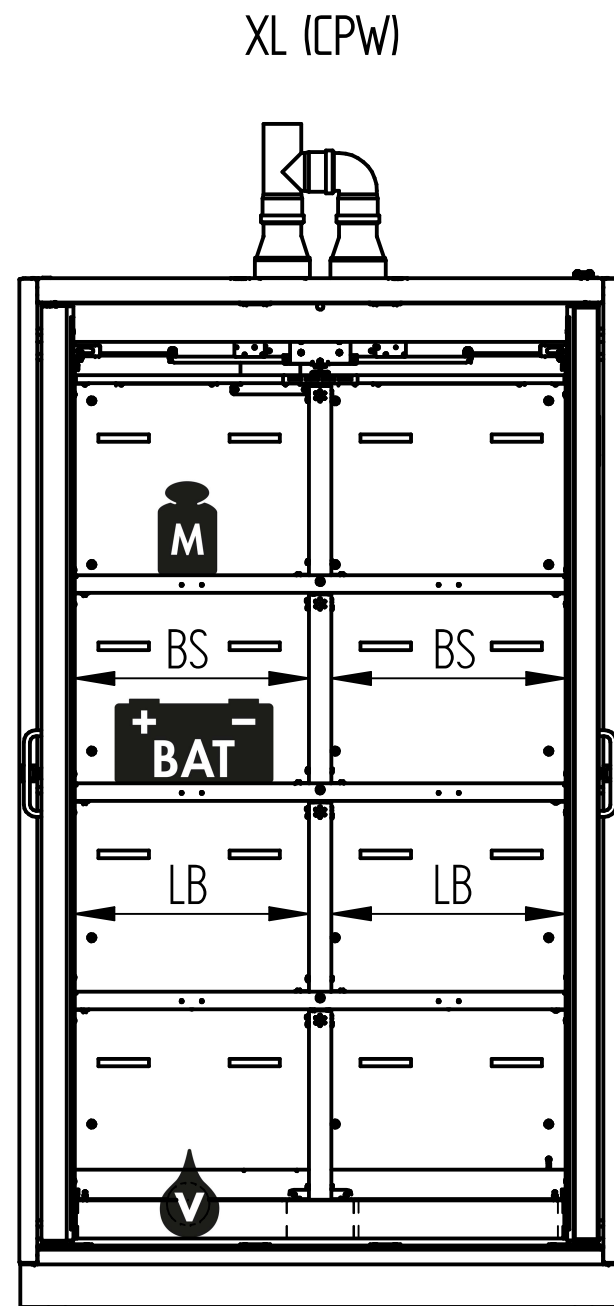
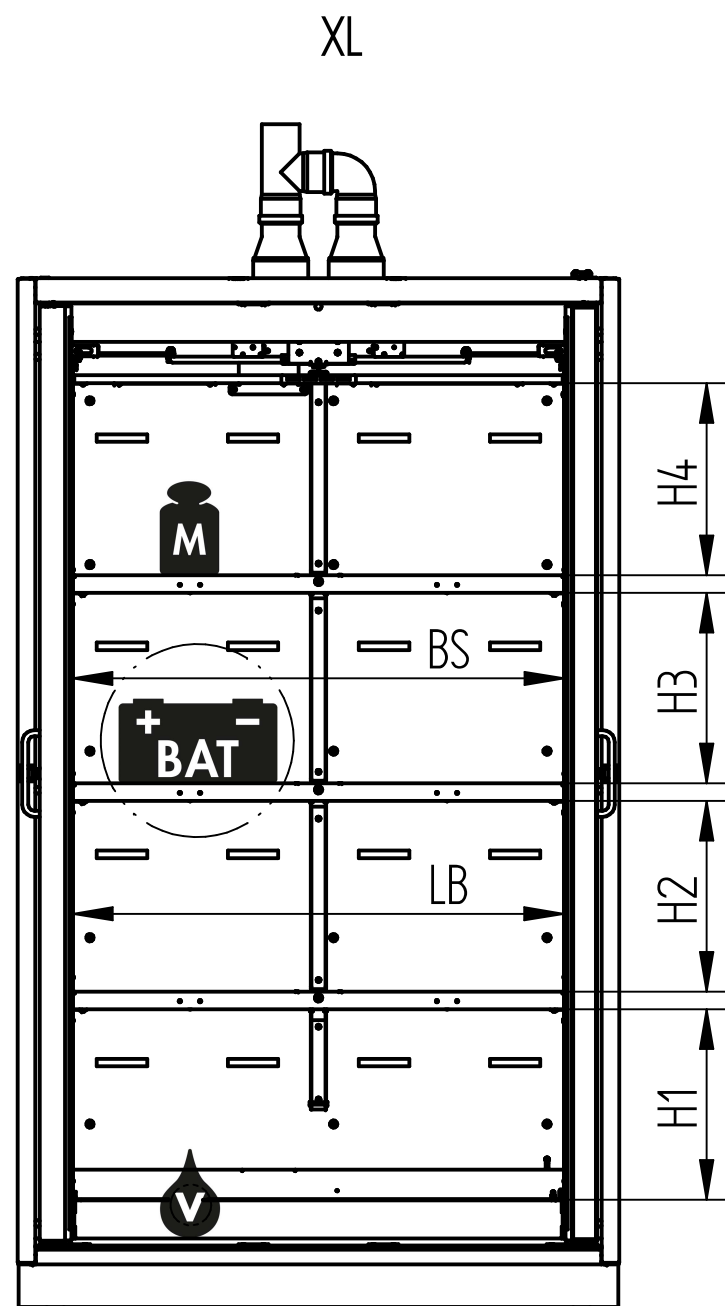

	Model type				
	S	XS	M	XL	XL (CPW)
BS (mm)	375	975	375	975	2x 465
TS (mm)	457	457	457	457	457
M (kg)	75	75	75	75	75
Max. load capacity (kg)	240	240	360	360	360
V (l)	11	33	11	33	33
LB (mm)	374	974	374	974	2x 464
K (Ah)	54	54	54	54	54
Number of storage levels	3	3	4	4	4
Number of storage areas	3	3	4	4	8

BS: Width storage area  
 TS: Depth storage area  
 M: Load bearing capacity per storage level (uniformly distributed)  
 V: Max. collection volume  
 LB: Clear width  
 CPW: Centre partition wall  
 BAT: Battery - may consist of several lithium-ion cells (K)  
 K: Max. capacity of the largest single lithium-ion cell

Max. setting height (mm)			
	Model type		
	S, XS	M, XL, XL (CPW)	
Storage levels	H1	297	378
	H2	297	378
	H3	---	378
	H4	299	381

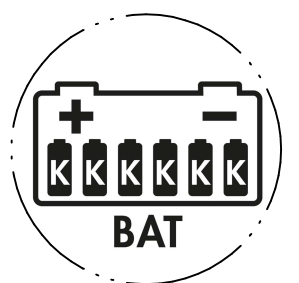

Inner dimensions

This drawing is our property! Furnish this information to other persons and reproduce or copy is not permitted without our written permission.	title: Safety cabinet type 90 BATTERY standard	
	drawing no: 000104997	page: 2 of 4
Düperthal Sicherheitstechnik Frankenstrasse 3 D-63791 Karlstein	revision: 02	date: 2020-03-19
<b>DÜPERTHAL</b>		

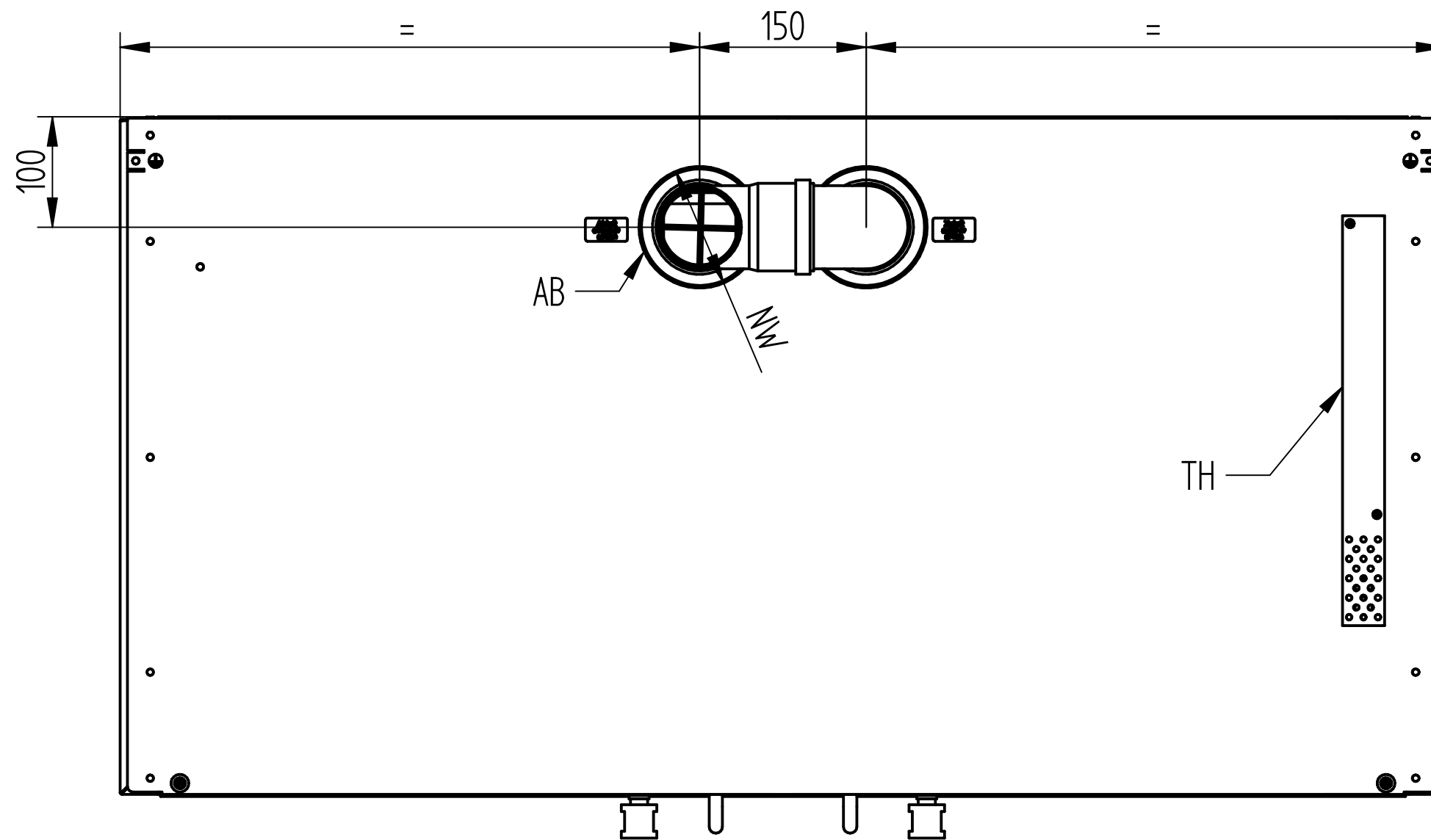

NW: 110, with adapter 75  
 AB: Exhaust air connection  
 TH: Thermocouple

### Ventilation connection

This drawing is our property! Furnish this information to other persons and reproduce or copy is not permitted without our written permission.	title: Safety cabinet type 90 BATTERY standard		
	drawing no: 000104997	page: 3 of 4	
Düperthal Sicherheitstechnik Frankenstrasse 3 D-63791 Karlstein	revision: 02	date: 2020-03-19	

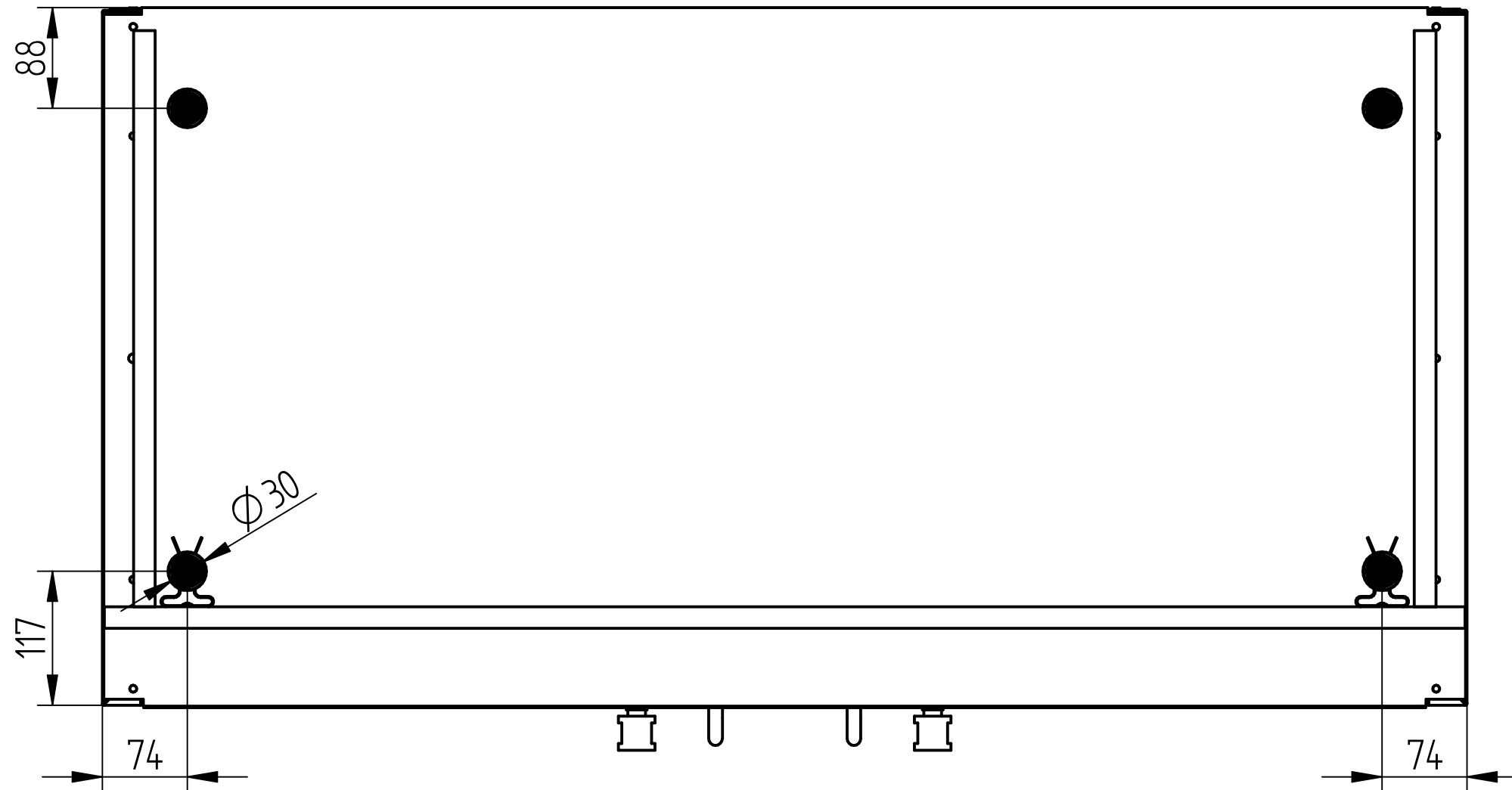

● Loaded footprint

### Geometry of the adjustable feet

This drawing is our property! Furnish this information to other persons and reproduce or copy is not permitted without our written permission.	title: Safety cabinet type 90 BATTERY standard		
	drawing no.: 000104997	page: 4 of 4	
Düperthal Sicherheitstechnik Frankenstrasse 3 D-63791 Karlstein	revision: 02	date: 2020-03-19	